



NER GROUP CO.,LIMITED

Yantai Bonway Manufacturer Co.,Ltd



YEJ2 系列电磁制动三相异步电动机

YEJ2 Series AC Squirrel-cage Brake Motors



机座号: 80~315

功率 0.18~200kW

制动方式: 失电制动

整流方式: 半波整流

适用于: 各类机床、印刷机械、锻压机、运输机械、包装机械、食品机械、建筑机械、木工机械等要求快速停止、准确定位、往复运转、防止滑行的各种机械中作主轴传动和辅助传动。

Applications: Widely used on mechanical equipment and driving machines where rapidly and accurate braking is demanded.

特点: 制动迅速, 结构简单, 定位准确。

Features: Spring set brake. Power off operation manual release. Resets automatically. One-half period rectification.

性能数据 Performance Data

380V 50Hz

型号 Type	功率 kW	额定 电流 A	转速 r/min	效率 Eff. %	功率 因数 P.F	额定 转矩 N.m	堵转转矩 额定转矩 $\frac{T_{st}}{T_N}$	堵转电流 额定电流 $\frac{I_{st}}{I_N}$	最大转矩 额定转矩 $\frac{T_{max}}{T_N}$
同步转速 3000 r/min									
YEJ2-80M1-2	0.75	1.8	2845	75.0	0.83	2.5	2.2	6.1	2.3
YEJ2-80M2-2	1.1	2.6	2845	76.2	0.84	3.7	2.2	7.0	2.3
YEJ2-90S-2	1.5	3.5	2840	78.5	0.84	5.0	2.2	7.0	2.3
YEJ2-90L-2	2.2	4.9	2840	81.0	0.85	7.4	2.2	7.5	2.3
YEJ2-100L-2	3	6.3	2860	82.6	0.87	10.0	2.2	7.5	2.3
YEJ2-112M-2	4	8.2	2880	84.2	0.88	13.3	2.2	7.5	2.3
YEJ2-132S1-2	5.5	11.1	2900	85.7	0.88	18.1	2.2	7.5	2.3
YEJ2-132S2-2	7.5	14.9	2900	87.0	0.88	24.7	2.2	7.5	2.3
YEJ2-160M1-2	11	21.2	2930	88.4	0.89	35.9	2.2	7.5	2.3
YEJ2-160M2-2	15	28.6	2930	89.4	0.89	48.9	2.2	7.5	2.3
YEJ2-160L-2	18.5	34.7	2930	90.0	0.90	60.3	2.2	7.5	2.3
YEJ2-180M-2	22	41.0	2940	90.5	0.90	71.5	2.0	7.5	2.3
YEJ2-200L1-2	30	55.4	2950	91.4	0.90	97.1	2.0	7.5	2.3
YEJ2-200L2-2	37	67.9	2950	92.0	0.90	120	2.0	7.5	2.3
YEJ2-225M-2	45	82.1	2960	92.5	0.90	145	2.0	7.5	2.3
YEJ2-250M-2	55	99.8	2965	93.0	0.9	177	2.0	7.5	2.3
YEJ2-280S-2	75	135	2970	93.6	0.90	241	2.0	7.5	2.3
YEJ2-280M-2	90	160	2970	93.9	0.91	289	2.0	7.5	2.3
YEJ2-315S-2	110	195	2975	94.0	0.91	353	1.8	7.1	2.2
YEJ2-315M-2	132	233	2975	94.5	0.91	424	1.8	7.1	2.2
YEJ2-315L1-2	160	279	2975	94.6	0.92	514	1.8	7.1	2.2
YEJ2-315L2-2	200	348	2975	94.8	0.92	642	1.8	7.1	2.2

性能数据 Performance Data

380V 50Hz

型号 Type	功率 kW	额定 电流 A	转速 r/min	效率 Eff.%	功率 因数 P.F	额定 转矩 N.m	堵转转矩 额定转矩 $\frac{T_{st}}{T_N}$	堵转电流 额定电流 $\frac{I_{st}}{I_N}$	最大转矩 额定转矩 $\frac{T_{max}}{T_N}$
同步转速 1500 r/min									
YEJ2-80M1-4	0.55	1.6	1390	71.0	0.75	3.8	2.4	5.2	2.3
YEJ2-80M2-4	0.75	2.1	1390	73.0	0.76	5.2	2.3	6.0	2.3
YEJ2-90S-4	1.1	2.8	1390	76.2	0.77	7.6	2.3	6.0	2.3
YEJ2-90L-4	1.5	3.7	1390	78.5	0.79	10.3	2.3	6.0	2.3
YEJ2-100L1-4	2.2	5.1	1410	81.0	0.81	14.9	2.3	7.0	2.3
YEJ2-100L2-4	3	6.7	1410	82.6	0.82	20.3	2.3	7.0	2.3
YEJ2-112M-4	4	8.8	1440	84.2	0.82	26.6	2.3	7.0	2.3
YEJ2-132S-4	5.5	11.7	1440	85.7	0.83	36.5	2.3	7.0	2.3
YEJ2-132M-4	7.5	15.6	1440	87.0	0.84	49.7	2.3	7.0	2.3
YEJ2-160M-4	11	22.5	1460	88.4	0.84	72.0	2.2	7.0	2.3
YEJ2-160L-4	15	30.0	1460	89.4	0.85	98.1	2.2	7.5	2.3
YEJ2-180M-4	18.5	36.3	1470	90.0	0.86	120	2.2	7.5	2.3
YEJ2-180L-4	22	42.9	1470	90.5	0.86	143	2.2	7.5	2.3
YEJ2-200L-4	30	58.0	1470	91.4	0.86	195	2.2	7.2	2.3
YEJ2-225S-4	37	70.2	1475	92.0	0.87	240	2.2	7.2	2.3
YEJ2-225M-4	45	85.0	1475	92.5	0.87	291	2.2	7.2	2.3
YEJ2-250M-4	55	103	1480	93.0	0.87	355	2.2	7.2	2.3
YEJ2-280S-4	75	140	1480	93.6	0.87	484	2.2	7.2	2.3
YEJ2-280M-4	90	167	1480	93.9	0.87	581	2.2	7.2	2.3
YEJ2-315S-4	110	201	1480	94.5	0.88	710	2.1	6.9	2.2
YEJ2-315M-4	132	240	1480	94.8	0.88	852	2.1	6.9	2.2
YEJ2-315L1-4	160	288	1480	94.9	0.89	1032	2.1	6.9	2.2
YEJ2-315L2-4	200	360	1480	94.9	0.89	1291	2.1	6.9	2.2
同步转速 1000 r/min									
YEJ2-80M1-6	0.37	1.3	885	62.0	0.7	4.0	1.9	4.7	2.1
YEJ2-80M2-6	0.55	1.8	885	65.0	0.72	5.9	1.9	4.7	2.1
YEJ2-90S-6	0.75	2.3	910	69.0	0.72	7.9	2.0	5.5	2.1
YEJ2-90L-6	1.1	3.2	910	72.0	0.73	11.5	2.0	5.5	2.1
YEJ2-100L-6	1.5	4.0	920	76.0	0.75	15.6	2.0	5.5	2.1
YEJ2-112M-6	2.2	5.6	935	79.0	0.76	22.5	2.0	6.5	2.1
YEJ2-132S-6	3	7.4	960	81.0	0.76	29.8	2.1	6.5	2.1
YEJ2-132M1-6	4	9.8	960	82.0	0.76	39.8	2.1	6.5	2.1
YEJ2-132M2-6	5.5	12.9	965	84.0	0.77	54.4	2.1	6.5	2.1
YEJ2-160M-6	7.5	17.2	970	86.0	0.77	73.8	2.0	6.5	2.1
YEJ2-160L-6	11	24.5	970	87.5	0.78	108	2.0	6.5	2.1
YEJ2-180L-6	15	31.6	970	89.0	0.81	148	2.0	7.0	2.1
YEJ2-200L1-6	18.5	38.6	980	90.0	0.81	180	2.1	7.0	2.1
YEJ2-200L2-6	22	44.7	980	90.0	0.83	214	2.1	7.0	2.1

性能数据 Performance Data

380V 50Hz

型号 Type	功率 kW	额定 电流 A	转速 r/min	效率 Eff. %	功率 因数 P.F	额定 转矩 N.m	堵转转矩 额定转矩 $\frac{T_{st}}{T_N}$	堵转电流 额定电流 $\frac{I_{st}}{I_N}$	最大转矩 额定转矩 $\frac{T_{max}}{T_N}$
同步转速 1000 r/min									
YEJ2-225M-6	30	59.3	980	91.5	0.84	292	2.0	7.0	2.1
YEJ2-250M-6	37	71.1	980	92.0	0.86	361	2.1	7.0	2.1
YEJ2-280S-6	45	85.9	980	92.5	0.86	439	2.1	7.0	2.0
YEJ2-280M-6	55	105	980	92.8	0.86	536	2.1	7.0	2.0
YEJ2-315S-6	75	142	985	93.5	0.86	727	2.0	6.7	2.0
YEJ2-315M-6	90	170	985	93.8	0.86	873	2.0	6.7	2.0
YEJ2-315L1-6	110	207	985	94.0	0.86	1066	2.0	6.7	2.0
YEJ2-315L2-6	132	245	985	94.2	0.87	1280	2.0	6.7	2.0
同步转速 750 r/min									
YEJ2-80M1-8	0.18	0.88	645	51.0	0.61	2.7	1.8	3.3	1.9
YEJ2-80M2-8	0.25	1.2	645	54.0	0.61	3.7	1.8	3.3	1.9
YEJ2-90S-8	0.37	1.5	670	62.0	0.61	5.3	1.8	4.0	1.9
YEJ2-90L-8	0.55	2.2	670	63.0	0.61	7.8	1.8	4.0	2.0
YEJ2-100L1-8	0.75	2.4	680	71.0	0.67	10.5	1.8	4.0	2.0
YEJ2-100L2-8	1.1	3.3	680	73.0	0.69	15.4	1.8	5.0	2.0
YEJ2-112M-8	1.5	4.4	690	75.0	0.69	20.8	1.8	5.0	2.0
YEJ2-132S-8	2.2	6.0	705	78.0	0.71	29.8	1.8	6.0	2.0
YEJ2-132M-8	3	7.9	705	79.0	0.73	40.6	1.8	6.0	2.0
YEJ2-160M1-8	4	10.3	720	81.0	0.73	53.1	1.9	6.0	2.0
YEJ2-160M2-8	5.5	13.6	720	83.0	0.74	73.0	2.0	6.0	2.0
YEJ2-160L-8	7.5	17.8	720	85.5	0.75	99.5	2.0	6.0	2.0
YEJ2-180L-8	11	25.1	730	87.5	0.76	144	2.0	6.6	2.0
YEJ2-200L-8	15	34.1	730	88.0	0.76	196	2.0	6.6	2.0
YEJ2-225S-8	18.5	41.1	730	90.0	0.76	242	1.9	6.6	2.0
YEJ2-225M-8	22	47.4	730	90.5	0.78	288	1.9	6.6	2.0
YEJ2-250M-8	30	63.4	735	91.0	0.79	390	1.9	6.6	2.0
YEJ2-280S-8	37	77.8	735	91.5	0.79	481	1.9	6.6	2.0
YEJ2-280M-8	45	94.1	735	92.0	0.79	585	1.9	6.6	2.0
YEJ2-315S-8	55	111	735	92.8	0.81	715	-	6.6	2.0
YEJ2-315M-8	75	151	735	93.0	0.81	974	-	6.6	2.0
YEJ2-315L1-8	90	178	735	93.8	0.82	1169	-	6.6	2.0
YEJ2-315L2-8	110	217	735	94.0	0.82	1429	-	6.6	2.0
同步转速 600 r/min									
YEJ2-315S-10	45	99.6	590	91.5	0.75	728	1.5	6.2	2.0
YEJ2-315M-10	55	121	590	92.0	0.75	890	1.5	6.2	2.0
YEJ2-315L1-10	75	162	590	92.5	0.76	1214	1.5	6.2	2.0
YEJ2-315L2-10	90	191	590	93.0	0.77	1457	1.5	6.2	2.0

外形及安装尺寸 Dimensions

mm

B3

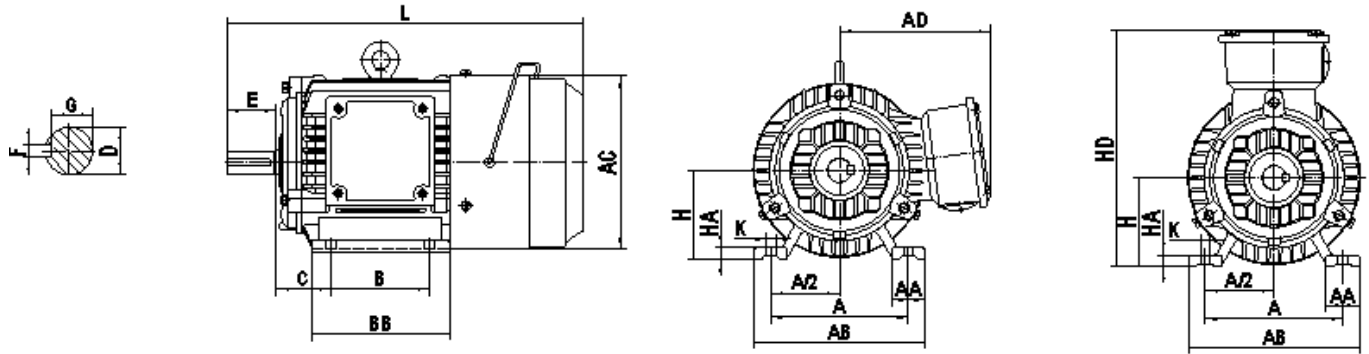

机座号 Frame	极数 Poles	安 装 尺 寸 Mounting Dimension									外 形 尺 寸 Overall Dimension								
		A	B	C	D	E	F	G	H	K	AA	BB	HA	AB	AC	AD	HD	L	
80M	2,4,6,8	125	100	50	19	40	6	155	80	10	32	135	10	160	165	145	225	355	
90S	2,4,6,8	140	100	56	24	50	8	20	90	10	34	145	12	180	180	165	255	395	
90L			125									170						420	
100L	2,4,6,8	160	140	63	28	60	8	24	100	12	39	186	14	200	205	175	275	465	
112M	2,4,6,8	190	140	70	28	60	8	24	112	12	45	200	14	230	225	190	300	515	
132S	2,4,6,8	216	140	89	38	80	10	33	132	12	55	190	18	265	270	220	350	570	
132M			178									230						605	
160M	2,4,6,8	254	210	108	42	110	12	37	160	15	65	260	20	315	320	260	420	705	
160L			254									304						750	
180M	2,4,6,8	279	241	121	48	110	14	425	180	15	70	311	22	355	360	265	445	785	
180L			279									349						820	
200L	2,4,6,8	318	305	133	55	110	16	49	200	19	74	379	26	395	400	305	505	910	
225S	4,8	356	286	149	60	140	18	53	225	19	78	375	28	435	450	325	550	940	
225M	2		311		55	110	16	49				400						935	
	4,6,8		60		140	18	53	965											
250M	2 4,6,8	406	349	168	60 65	140	18	53 58	250	24	80	445	30	490	510	380	630	1050	
280S	2 4,6,8	457	368	190	65	140	18	58	280	24	90	485	35	545	550	395	675	1095	
280M	2				75		20	67.5										536	
	4,6,8		65		18		58												
	2		75		20		67.5												
315S	2 4,6,8,10	508	406	216	65	140	18	58	315	28	120	570	45	635	630	540	855	1335	
315M	2				80	170	22	71										1370	
	4,6,8,10		65		140	18	58	1400											
315L	2		508		457	65	140	18				58						680	1445
	4,6,8,10					80	170	22				71							1475

B5

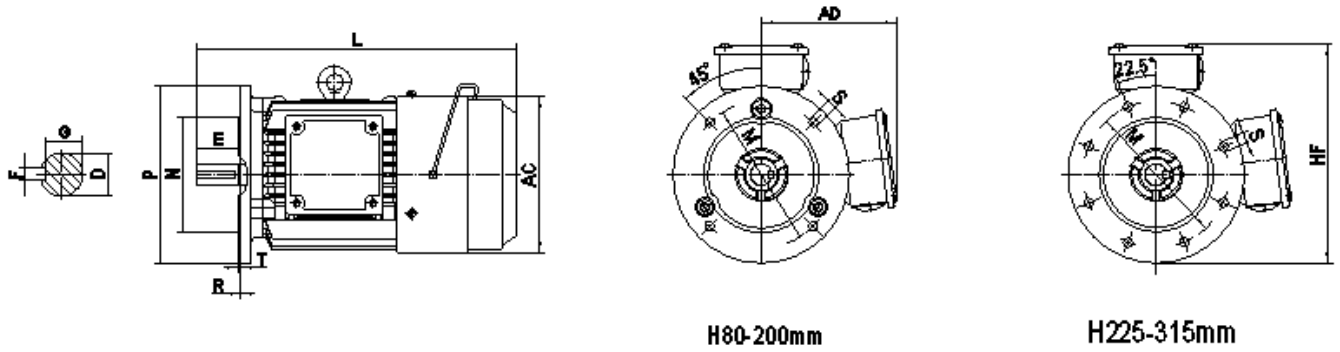

机座号 Frame	极数 Poles	安 装 尺 寸 及 公 差 Mounting Dimension										外 形 尺 寸 Overall Dimension			
		D	E	F	G	M	N	P	R	S	T	AC	AD	HF	L
80M	2,4,6,8	19	40	6	15.5	165	130	200	0	4-Φ12	3.5	165	145	245	355
90S	2,4,6,8	24	50	8	20	165	130	200	0	4-Φ12	3.5	180	165	265	395
90L															420
100L	2,4,6,8	28	60	8	24	215	180	250	0	4-Φ15	4	205	175	300	465
112M	2,4,6,8	28	60	8	24	215	180	250	0	4-Φ15	4	225	190	315	515
132S	2,4,6,8	38	80	10	33	265	230	300	0	4-Φ15	4	275	220	370	570
132M															605
160M	2,4,6,8	42	110	12	37	300	250	350	0	4-Φ19	5	320	260	435	705
160L															750
180M	2,4,6,8	48	110	14	42.5	300	250	350	0	4-Φ19	5	360	265	440	785
180L															820
200L	2,4,6,8	55	110	16	49	350	300	400	0	4-Φ19	5	400	305	505	910
225S	4,8	60	140	18	53	400	350	450	0	8-Φ19	5	450	325	550	940
225M	2	55	110	16	49										935
	4,6,8	60	140	18	53										965
250M	2	60	140	18	53	500	450	550	0	8-Φ19	5	510	380	655	1050
	4,6,8	65			58										
280S	2	65	140	18	58	500	450	550	0	8-Φ19	5	550	395	670	1095
	4,6,8	75		20	67.5										
280M	2	65		18	58										1145
	4,6,8	75		20	67.5										

B35

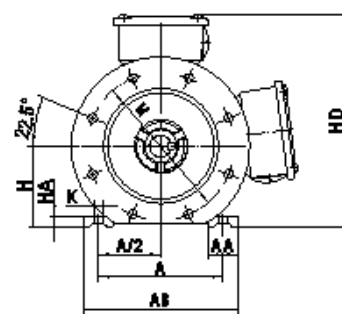
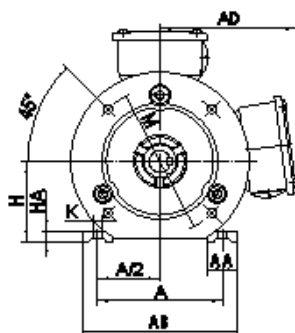
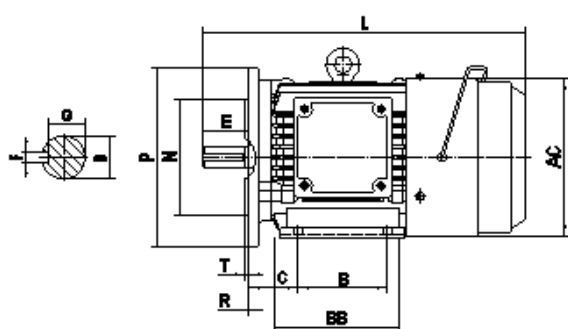

H80-200mm

H225-315mm

机座号 Frame	极数 Poles	安 装 尺 寸 及 公 差 Mounting Dimension														外 形 尺 寸 Overall Dimension										
		A	B	C	D	E	F	G	H	K	M	N	P	R	S	T	AA	BB	HA	AB	AC	AD	HD	L		
80M	2,4,6,8	125	100	50	19	40	6	15.5	80	10	165	130	200	0	4-Φ12	3.5	32	135	10	160	165	145	225	355		
90S	2,4,6,8	140	100	56	24	50	8	20	90	10	165	130	200	0	4-Φ12	3.5	34	145	12	180	180	165	255	395		
90L			125															170							420	
100L	2,4,6,8	160	140	63	28	60	8	24	100	12	215	180	250	0	4-Φ15	4	39	186	14	200	205	175	275	465		
112M	2,4,6,8	190	140	70	28	60	8	24	112	12	215	180	250	0	4-Φ15	4	45	200		230	225	190	300	515		
132S	2,4,6,8	216	140	89	38	80	10	33	132	12	265	230	300	0	4-Φ15	4	55	190	18	265	270	220	350	570		
132M			178															230							605	
160M	2,4,6,8	254	210	108	42	110	12	37	160	15	300	250	350	0	4-Φ19	5	65	260	20	315	320	260	420	705		
160L			254															304							750	
180M	2,4,6,8	279	241	121	48	110	14	42.5	180	15	300	250	350	0	4-Φ19	5	70	311	22	355	360	265	445	785		
180L			279															349							820	
200L	2,4,6,8	318	305	133	55	110	16	49	200	19	350	300	400	0	4-Φ19	5	74	379	26	395	400	305	505	910		
225S	4,8	356	286	149	60	140	18	53	225	19	400	350	450	0	8-Φ19	5	78	375	28	435	450	325	550	940		
225M	2		311		55	110	16	49										53							400	935
	4,6,8		60		140	53	965																			
250M	2	406	349	168	60	140	18	58	250	24	500	450	550	0	8-Φ19	5	80	445	30	490	510	380	630	1050		
	4,6,8				65	58																				
280S	2	457	368	190	65	140	20	67.5	280	24	500	450	550	0	8-Φ19	5	90	485	35	545	550	395	675	1095		
	4,6,8				75													58								
280M	2	419	368	190	65	140	20	67.5	280	24	500	450	550	0	8-Φ19	5	90	536	35	545	550	395	675	1145		
	4,6,8				75													58								
315S	2	508	406	216	65	140	18	58	315	28	600	550	660	0	8-Φ24	6	120	570	45	635	630	540	855	1335		
	4,6,8,10				80	170	22	71										1365								
315M	2	508	457	216	65	140	18	58	315	28	600	550	660	0	8-Φ24	6	120	610	45	635	630	540	855	1370		
	4,6,8,10				80	170	22	71										1400								
315L	2	508	457	216	65	140	18	58	315	28	600	550	660	0	8-Φ24	6	120	680	45	635	630	540	855	1445		
	4,6,8,10				80	170	22	71										1475								

制动器技术参数

Technical Data of The Brake

机座号 Frame	衔铁最大行程（气隙） Stroke of the Armature mm	空载制动时间 No-load braking time ms	制动力矩 Braking torque N·m	励磁电压（DC） Excitation Voltage V	制动器励磁功率 Brake Excitation Power W
YEJ2-80	1.0	72	7.5	100	50
YEJ2-90	1.0	95	15	100	60
YEJ2-100	1.0	120	30	100	80
YEJ2-112	1.0	130	40	170	110
YEJ2-132	1.2	140	80	170	130
YEJ2-160	1.2	180	150	170	150
YEJ2-180	1.2	210	200	170	150
YEJ2-200	1.5	250	300	170	200
YEJ2-225	1.5	270	450	170	200
YEJ2-250	1.6	285	600	170	210
YEJ2-280	1.8	320	850	170	340
YEJ2-315	1.8	375	2000	170	400

常用的安装结构型式，以及适用的机座号见下表

Conventional mounting type and suitable frame size are given in following table (with “√”)

机座号 Frame	基本安装结构			派生的安装形式											
	B3	B5	B35	V1	V3	V5	V6	B6	B7	B8	V15	V36	B14	B34	V18
80~112	√	√	√	√	√	√	√	√	√	√	√	√	√	√	√
132~160	√	√	√	√	√	√	√	√	√	√	√	√	-	-	-
180~280	√	√	√	√	-	-	-	-	-	-	-	-	-	-	-
315	√	-	√	√	-	-	-	-	-	-	-	-	-	-	-

“√”表示可以制造生产的结构型式，电机订购时，若不作说明的接线盒为侧式右出线

Always chase the first since 1995

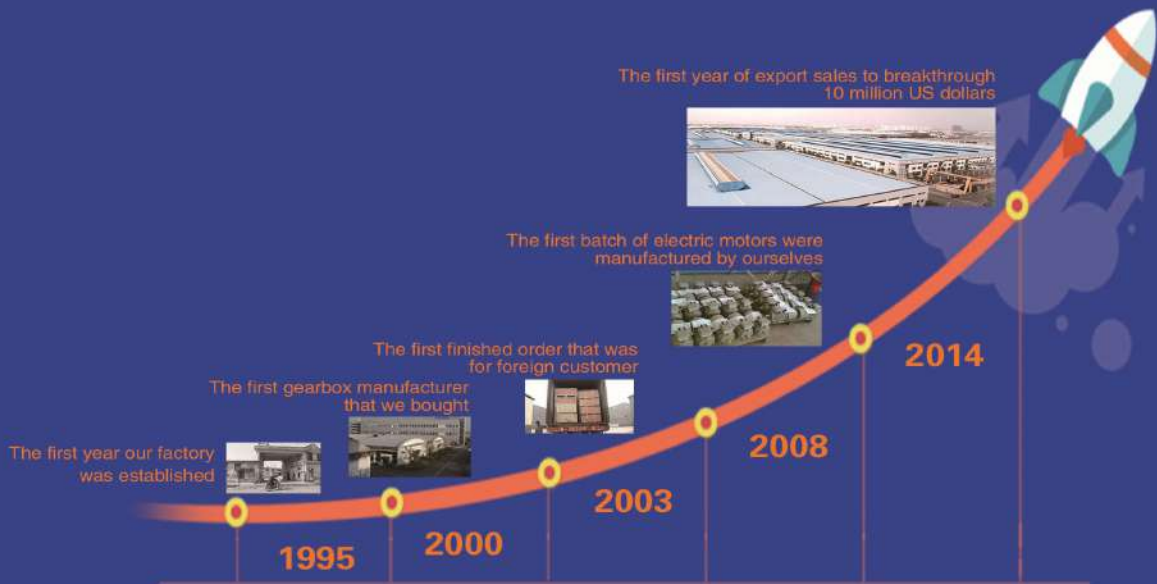

Tel:+86-535-6330966

Mobile:+86-18563806647

E-mail: info@sogears.com

Viber/Line/Whatsapp/Wechat: 008618563806647

Web: www.sogears.com(Skype: qingdao411)

Headquarters Address: Wujin, Changzhou City, Jiangsu Province,China