



NER GROUP CO.,LIMITED

Yantai Bonway Manufacturer Co.,Ltd



Z Series cylindrical gear reducer

Cylinder Gearbox Reducer

Summary: This product is cylindrical gear hard surface speed reducer as Chinese standard JB/T8853-2001. It is widely applied to the fields of metallurgy, mines, hoisting, transportation, cement, architecture, chemical, textile, printing and dyeing, pharmaceutical, etc.

The suitable scope of speed reducer is as follows:

1. The rotation of high speed shaft should not be more than 1500rpm;
2. The circumferential velocity of gear transmission should not be more than 20,/sec;
3. The temperature of work environment should be -40-45℃. If it below 0℃, before start, the lubricating oil should be pre-heated to above 0℃. This speed reducer can be run at clockwise and counterclockwise direction.

Characteristics

1. The gear is made of high strength low carbon alloy steel through carburization and quenching. The hardness of tooth surface may reach to HRC58-62. All gear adapts NC tooth grinding process, high in accuracy and good in contact performance;
2. Highly transmission efficiency: single stage, more than 96.5%; double-stage, more than 93%; three-stage, more 90%;
3. Smooth and stable in run, low noise;
4. Compact, light, long life, high bearing capacity;. Easy to disassemble, inspect and assemble.

Type, specification of speed reducer and its expressed method

1. The type including: ZDY single-stage cylindrical gear speed reducer, ZLY double-stage cylindrical gear speed reducer, ZSY three-stage cylindrical gear speed reducer
2. Specification has: Single stage: 80、100、125、160、200、250、280、315、355、400、450、500、560;
Two-stage: 112、125、140、160、180、200、224、250、280、315、355、400、450、500、560、630、710;
Three-stage: 160、180、200、224、250、280、315、355、400、450、500、560、630、710;
Four-stage: 180、200、225、250、280、320、360、450、500、560、630、710、800

3. Representation examples:

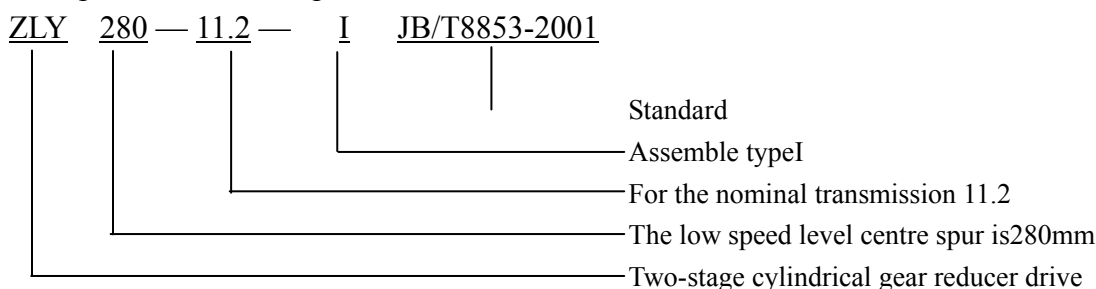

4. Only allow to single direction running for reducer with hold back. Regulation is face to input shaft, input shaft 's running as "S" clockwise ,running as "N" counter-clockwise

3、 The appearance, assembly and installation dimensions。

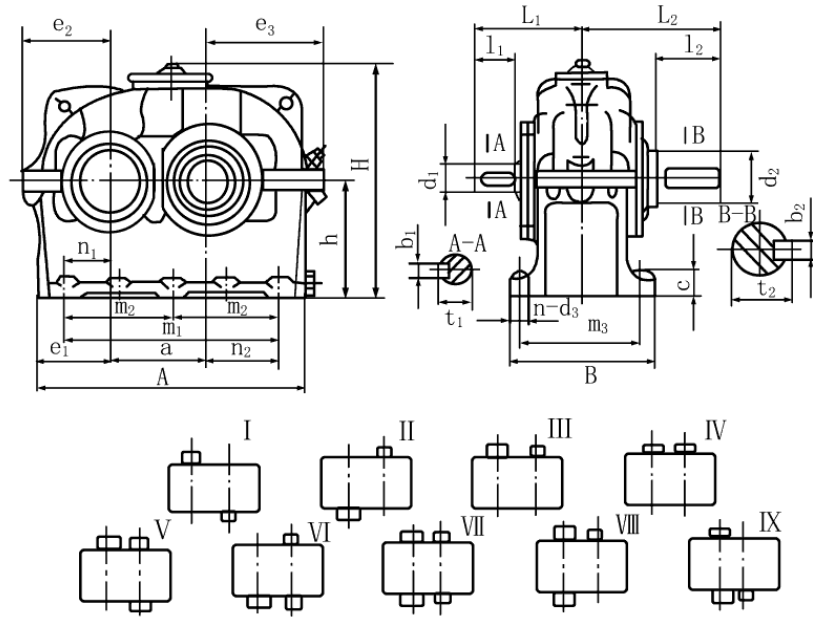

1、 ZDY Series

ZDY	A	B	H≈	a	i=1.25~2.8					i=3.15~4.5					i=5~5.6					Weigh	oilL
					d ₁ (m6)	l ₁	L ₁	b ₁	t ₁	d ₁ (m6)	l ₁	L ₁	b ₁	t ₁	d ₁ (m6)	l ₁	L ₁	b ₁	t ₁		
80	235	150	210	80	28	42	112	8	31	24	36	106	8	27	19	28	98	6	21.5		
100	290	175	260	100	42	82	167	12	45	28	42	127	8	31	22	36	121	6	24.5		
125	355	195	330	125	48	82	182	14	51.5	38	58	158	10	41	28	42	142	8	31		
160	445	245	403	160	65	105	225	18	69	48	82	202	14	51.5	38	58	178	10	41		
200	545	310	507	200	80	130	275	22	85	60	105	250	18	64	48	82	227	14	51.5		
250	680	370	662	250	100	165	340	28	106	80	130	305	22	85	60	105	280	18	64		
280	755	450	722	280	110	165	385	28	116	85	130	350	22	90	65	105	325	18	69		
315	840	500	770	315	130	200	445	32	137	95	130	375	25	100	75	105	350	20	79.5		
355	930	550	930	355	140	200	470	36	148	100	165	435	28	106	90	130	400	25	95		
400	1040	605	982	400	150	200	485	36	158	110	165	450	28	116	95	130	415	25	100		
450	1150	645	1090	450	160	240	545	40	169	120	165	470	32	127	100	165	470	28	106		
500	1290	710	1270	500	180	240	580	45	190	130	200	540	32	137	120	165	505	32	127		
560	1440	780	1360	560	200	280	660	45	210	150	200	580	36	158	130	200	580	32	137		
ZDY	d ₂ (m6)	l ₂	L ₂	b ₂	t ₂	C	m ₁	m ₂	m ₃	n ₁	n ₂	e ₁	e ₂	e ₃	h	Bolt hole		Weigh	oilL		
																d ₃	n				
80	32	58	128	10	35	18	180	—	120	40	60	67.5	81	101	100	12	4	14	0.9		
100	48	82	167	14	51.5	22	225	—	140	52.5	72.5	85	102	122	125	15	4	35	1.6		
125	55	82	182	16	59	25	290	—	160	65	100	97.5	119	155	160	15	4	76	3.2		
160	70	105	225	20	74.5	32	355	—	200	73	122	118	141	190	200	18.5	4	115	6.5		
200	90	130	275	25	95	40	425	—	255	80	145	140	169	235	250	24	4	228	12.5		
250	110	165	340	28	116	50	550	275	305	110	190	175	214	295	315	28	6	400	23		
280	130	200	420	32	137	50	620	310	380	120	220	187.5	228	328	355	28	6	540	36		
315	140	200	445	36	148	63	700	350	420	137.5	247.5	207.5	254	364	400	35	6	800	45		
355	150	200	470	36	158	63	770	385	470	142.5	272.5	222.5	269	397	450	35	6	1050	70		
400	160	240	525	40	169	80	850	425	510	150	300	245	304	454	500	42	6	1640	90		
450	170	240	545	40	179	80	950	475	550	165	335	265	331	501	560	42	6	2100	125		
500	190	280	620	45	200	100	1080	540	610	190	390	295	418	618	630	42	6	3100	180		
560	240	330	790	56	252	100	1200	600	680	205	435	325	432	662	710	48	6	3730	250		

ZDY Reducer power P_1

ratio <i>i</i>	The nominal		Specifications												
	input n_1	output n_2	80	100	125	160	200	250	280	315	355	400	450	500	560
			Input power P_1 /kW												
1.25	1500	1200	57	103	205	360	633	1121	—	—	—	—	—	—	—
	1000	800	40	69	140	260	446	807	—	—	—	—	—	—	—
	750	600	31	52	105	190	348	636	—	—	—	—	—	—	—
1.4	1500	1070	53	96	194	326	616	1109	—	—	—	—	—	—	—
	1000	715	37	65	132	240	433	794	—	—	—	—	—	—	—
	750	535	29	48	102	180	337	624	—	—	—	—	—	—	—
1.6	1500	940	49	92	180	310	587	1068	1473	1996	2766	—	—	—	—
	1000	625	34	63	125	217	410	760	1051	1430	1992	—	—	—	—
	750	470	27	50	98	168	319	595	824	1124	1569	—	—	—	—
1.8	1500	835	45	87	173	290	557	1024	1411	1925	2663	—	—	—	—
	1000	555	31	62	120	206	389	726	1002	1372	1906	—	—	—	—
	750	415	24	48	95	160	302	567	784	1074	1497	—	—	—	—
2	1500	750	39	80	158	278	526	970	1339	1827	2536	—	—	—	—
	1000	500	27	55	110	194	367	684	946	1296	1806	2547	3578	4793	—
	750	375	21	43	85	150	284	534	738	1013	1414	1999	2821	3775	5169
2.24	1500	670	36	70	141	264	484	914	1236	1711	2377	—	—	—	—
	1000	445	25	49	98	183	337	645	874	1207	1683	2402	3397	4512	—
	750	335	19	38	76	142	262	503	682	941	1314	1878	2667	3538	4833
2.5	1500	600	32	64	127	245	447	855	1154	1617	2264	—	—	—	—
	1000	400	22	45	88	170	311	601	812	1136	1596	2235	3185	4353	—
	750	300	17	35	68	132	241	468	633	884	1243	1742	2492	3406	4645
2.8	1500	535	27	53	115	224	409	789	1063	1489	2068	—	—	—	—
	1000	360	19	37	80	155	284	552	746	1048	1456	2049	2945	4000	—
	750	270	15	29	62	120	220	429	580	816	1134	1593	2296	3118	4232
3.15	1500	475	23	47	96	203	375	709	990	1359	1924	2658	3790	5036	6666
	1000	315	16	33	67	140	260	496	695	952	1352	1817	2681	3607	4807
	750	235	13	25	52	109	202	385	540	740	1052	1458	2084	2802	3747
3.55	1500	425	20	41	85	179	337	639	898	1210	1730	2410	3407	4460	6119
	1000	280	14	28	59	124	234	446	628	845	1210	1694	2396	3196	4395
	750	210	11	22	46	96	181	346	488	655	940	1312	1856	2483	3419
4	1500	375	17	34	69	155	300	570	774	1095	1555	2146	2981	3985	5651
	1000	250	12	24	48	107	208	396	539	764	1088	1501	2090	2838	4033
	750	187	9	18	37	83	161	307	418	590	844	1160	1618	2199	3128
4.5	1500	335	14	29	55	137	260	495	703	997	1367	1878	2619	3635	4912
	1000	220	9.5	20	38	95	180	344	488	694	953	1311	1832	2582	3485
	750	166	7	15	30	73	139	266	378	536	738	1015	1416	1997	2694
5	1500	300	11	25	48	121	229	451	608	864	1179	1680	2340	3149	4400
	1000	200	8	17	33	84	159	313	422	599	820	1168	1629	2231	3125
	750	150	6	13	26	65	123	242	326	462	633	900	1257	1724	2418
5.6	1500	270	10	20	40	109	211	389	531	779	1031	1564	2038	2791	3778
	1000	180	7	14	27	75	146	270	368	540	716	1088	1417	1969	2670
	750	134	5	11	21	59	113	208	285	416	554	838	1092	1519	2061

note: 1. The construction standard pattern no $i = 6.3$, using $i = 6.3$, need special design of gears and bearing structure.

2. Space of gear circumference speed $v > 20\text{m/s}$.

2、ZLY Series

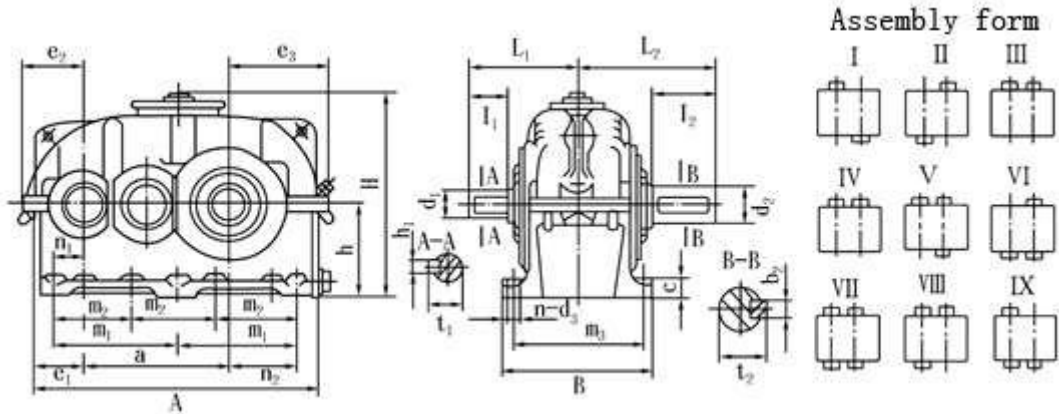

Specification	A	B	H ≈	a	i=63~112					i=125~20					d ₃ (m6)	t ₂	L ₂	b ₂	t ₂	
					d ₃ (m6)	t ₁	L ₁	b ₁	t ₁	d ₃ (m6)	t ₁	L ₁	b ₁	t ₁						
112	385	215	265	192	24	36	141	8	27	22	36	141	6	24.5	48	82	192	14	51.5	
125	425	235	309	215	28	42	157	8	31	24	36	151	8	27	55	82	197	16	59	
140	475	245	335	240	32	58	185	10	35	28	42	167	8	31	65	105	230	18	69	
160	540	290	375	272	38	58	198	10	41	32	58	198	10	35	75	105	245	20	79.5	
180	600	320	435	305	42	82	232	12	45	32	58	208	10	35	85	130	285	22	90	
200	665	355	489	340	48	82	247	14	51.5	38	58	223	10	41	95	130	300	25	100	
224	755	390	515	384	48	82	267	14	51.5	42	82	267	12	45	100	165	355	28	106	
250	830	450	594	430	60	105	315	18	64	48	82	292	14	51.5	110	165	380	28	116	
280	920	500	670	480	65	105	340	18	69	55	82	317	16	59	130	200	440	32	137	
315	1030	570	780	539	75	105	365	20	79.5	60	105	365	18	64	140	200	470	36	148	
355	1150	600	870	605	85	130	410	22	90	70	105	385	20	74.5	170	240	530	40	179	
400	1280	690	968	680	90	130	440	25	95	80	130	440	22	85	180	240	560	45	190	
450	1450	750	1065	765	100	165	515	28	106	85	130	480	22	90	220	280	640	50	231	
					i=63~125					i=14~20										
500	1600	830	1190	855	110	165	555	28	116	95	130	520	25	100	240	330	730	56	252	
560	1760	910	1320	960	120	165	575	32	127	110	165	575	28	116	280	380	820	63	292	
630	1980	1010	1480	1080	140	200	660	36	148	120	165	625	32	127	300	380	870	70	314	
710	2220	1110	1653	1210	160	240	740	40	169	140	200	700	36	148	340	450	990	80	355	

ZLY	C	m ₁	m ₂	m ₃	n ₁	n ₂	e ₁	e ₂	e ₃	h	Bolt hole		Weight kg	oilL
											d ₃	n		
112	22	160	—	180	43	85	75.5	92	134	125	15	6	60	3
125	25	180	—	200	45	100	77.5	98	153	140	15		69	4. 3
140	25	200	—	210	47.5	112.5	85	106	171	160	15		105	6
160	32	225	—	245	58	120	103	126	188	180	18.5	6	155	8. 5
180	32	250	—	275	60	135	110	134	209	200	18.5		185	11. 5
200	40	280	—	300	65	155	117.5	148	238	225	24		260	16. 5
224	40	310	—	335	70.5	165.5	137.5	168	263	250	24	6	370	23
250	50	350	—	380	80	190	145	184	293	280	28		527	32
280	50	380	—	430	75	205	155	195	325	315	28		700	46
315	63	420	—	490	78	223	173	219	364	355	35	940	65	

355	63	475	—	520	92.5	252.5	192.5	238	398	400	35	6	1250	90
400	80	520	—	590	95	265	215	275	445	450	42	6	1750	125
450	80	—	400	650	117.5	317.5	242.5	305	505	500	42	8	2650	180
500	100	—	440	710	120	345	262.5	337	557	560	48	8	3400	250
560	100	—	490	790	120	390	265	354	624	630	48		4500	350
630	125	—	540	870	115	425	295	384	694	710	56		6800	350
710	125	—	610	950	140	480	335	440	780	800	56		8509	520

ZLY Reducer power

ratio i	Speed		Specifications																
	/r·min		112	125	140	160	180	200	224	250	280	315	355	400	450	500	560	630	710
	input n1	output n2																	
6.3	1500	240	37.4	54	73	114	157	221	305	424	578	791	1156	1650	2192	3132	4310	—	—
	1000	160	26.4	37.4	50	78	109	153	211	294	400	548	802	1146	1558	2181	3000	4347	6229
	750	120	19.5	28.6	38.5	60	84	119	163	227	308	422	618	884	1213	1685	2320	3357	4884
7.1	1500	210	34	49	66	104	143	201	277	385	525	719	1051	1500	1993	2847	3817	—	—
	1000	140	24	34	45.5	71	99	139	192	267	364	498	729	1042	1416	1983	2731	3952	5663
	750	106	17.7	26	35	54.5	76	108	148	206	280	384	562	804	1103	1532	2109	3052	4440
8	1500	185	32	43	61	94.5	130	181.5	250	347	469	678	932	1309	1869	2489	3520	—	—
	1000	125	21.5	29.5	42.4	64	93	126	173	241	325	470	646	908	1298	1730	2447	3398	5019
	750	94	17	23	33	49	69	97	133	186	251	362	498	700	1000	1333	1887	2619	3881
9	1500	167	29	38.5	56	81	119	165.5	227	315	423	612	841	1182	1689	2248	3183	—	—
	1000	111	20	27	38.5	55	82.5	115	157	218	293	424	583	819	1172	1561	2210	3068	4537
	750	83	15	20.5	30	42	64	88	121	168	226	327	449	631	903	1202	1703	2363	3502
10	1500	150	26	35	50	73	109	149	204	284	383	555	762	1070	1530	2038	2883	—	—
	1000	100	18	24	35	50	75	103	142	197	266	384	528	742	1061	1414	2001	2777	4112
	750	75	14	18.5	26.6	38	58	80	109	152	204	296	407	571	817	1088	1541	2139	3172
11.2	1500	134	23	31.5	45	66	96	133	184	255	346	500	688	966	1381	1839	2604	—	—
	1000	89	16	22	31	45	67	92	127	177	240	347	477	669	957	1275	1806	2506	3711
	750	67	12	17	24	35	51	71	98	136	185	267	367	516	737	982	1391	1930	2862
12.5	1500	120	21	28	40	59	83	116.5	165	229	311	450	618	869	1242	1654	2341	—	—
	1000	80	14	19.5	28	40	57	81	114	159	216	312	428	601	860	1146	1621	2251	3338
	750	60	11	15	21	31	44	63	88	122	166	240	330	463	663	882	1249	1734	2573
14	1500	107	18.5	25	36	52.5	74	105	148	206	279	404	555	779	1115	1485	2162	2918	4318
	1000	71	12.5	17.5	25	36	51	73	102	142	193	280	384	540	772	1028	1455	2020	2996
	750	54	9.8	13	19	27.6	39	56	79	110	149	216	296	416	594	792	1120	1555	2310
16	1500	94	16	22	31	47.5	70.5	98	133	185	251	362	498	700	1000	1333	1887	2619	3879
	1000	62	11	15	21.5	32	49	68	92	128	174	251	345	484	693	923	1306	1812	2690
	750	47	8	11.5	17	25	38	53	71	99	134	193	266	373	533	711	1005	1395	2073
18	1500	83	14	19.5	28	42.5	60.5	86	115	161	225	326	448	629	899	1197	1697	2353	3487
	1000	56	10	13.5	19.6	29	42	59.5	80	111	156	226	310	435	622	829	1175	1628	2417
	750	42	7.5	10.5	15	22	32	46	61	86	120	174	239	335	479	638	905	1252	1861
20	1500	75	13	18	25.5	38	59	77	103	142	205	296	418	587	839	1120	1580	2200	3260
	1000	50	9	12	18	26.5	41	53.5	72	95	142	205	279	392	560	746	1050	1460	2170
	750	38	6.8	9.5	14	20	32	41	55	76	109	158	210	295	420	562	735	1120	1635

ZSY Series gear reducer

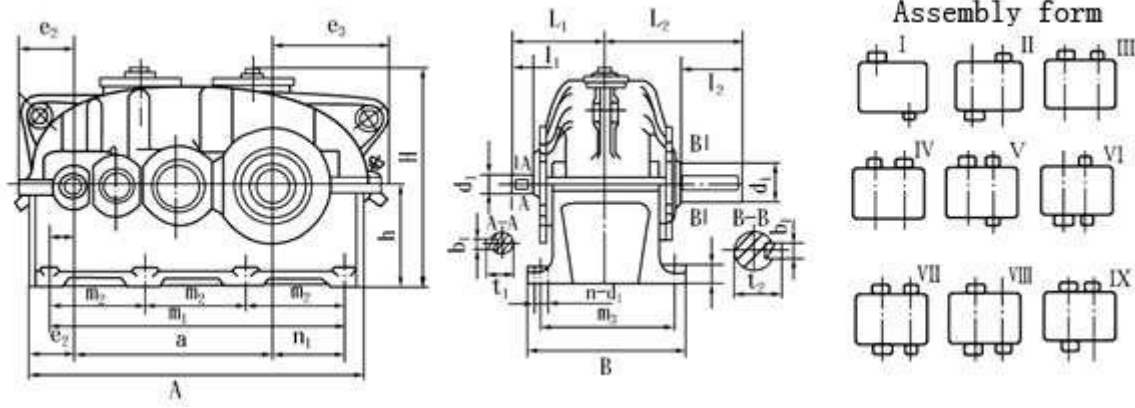

Specification	A	B	H ≈	a	i=22.4~71					i=80~100					d ₁ (m6)	b ₁	L ₂	b ₂	t ₂
					d ₁ (m6)	t ₁	L ₁	b ₁	t ₁	d ₁ (m6)	t ₁	L ₁	b ₁	t ₁					
160	600	290	375	352	24	36	166	8	27	19	28	158	6	21.5	75	105	245	20	79.5
180	665	320	435	395	28	42	187	8	31	22	36	181	6	24.5	85	130	285	22	90
200	745	355	492	440	32	58	218	10	35	22	36	196	6	24.5	95	130	300	25	100
224	840	390	535	496	38	58	233	10	41	24	36	211	8	27	100	165	355	28	106
250	930	450	589	555	42*	82*	282	12	45	32	58	258	10	35	110	165	380	28	116
280	1025	500	662	620	48	82	307	14	51.5	38	58	283	10	41	130	200	440	32	137
315	1160	570	749	699	48	82	337	14	51.5	42	82	337	12	45	140	200	470	36	148
					i=22.4~35.5					i=40~90									
355	1280	600	870	785	60	105	380	18	64	48	82	357	14	51.5	170	240	530	40	179
400	1420	690	968	880	65	105	410	18	69	55	82	387	16	59	180	240	560	45	190
450	1610	750	1067	989	70	105	450	20	74.5	60	105	450	18	64	220	280	640	50	231
					i=22.4~45					i=50~90									
500	1790	830	1170	1105	80	130	515	22	85	65	105	490	18	69	240	330	730	56	252
560	2010	910	1320	1240	95	130	530	25	100	75	105	505	20	79.5	280	380	820	63	292
630	2260	1030	1480	1395	110	165	625	28	116	85	130	590	22	90	300	380	880	70	314
710	2540	1160	1655	1565	120	165	685	32	127	90	130	650	25	95	340	450	1010	80	355

note* When i=63 and i=71, Axis stretch size d₁=32, l₁=58.

Specification	C	m ₁	m ₂	m ₃	n ₁	n ₂	e ₁	e ₂	e ₃	h	Bolt hole		Weight/kg	oil/L
											d ₃	n		
160	32	510	170	245	38	120	83	107	188	180	18.5	8	170	10
180	32	570	190	275	37.5	137.5	85	109	209	200	18.5		205	14
200	40	630	210	300	40	150	97.5	128	238	225	24		285	19
224	40	705	235	335	43.5	165.5	110.5	141	263	250	24	8	395	26
250	50	810	270	380	60	195	120	158	293	280	28		540	36
280	50	855	285	430	35	200	120	160	325	315	28		750	53
315	63	960	320	490	40	221	143	189	364	355	35		1030	78
355	63	1080	360	520	42.5	252.5	143	188	398	400	35	8	1400	115
400	80	1200	400	590	45	275	155	215	445	450	42		1950	160
450	80	1350	450	650	48	313	178	240	505	500	42		2636	220
500	100	1500	500	710	59	336	200	277	557	560	48		3800	300
560	100	1680	560	790	70	370	235	324	624	630	48	8	5100	450
630	125	1890	630	890	72.5	422.5	255	344	694	710	56		7060	520
710	125	2130	710	1000	92.5	472.5	297.5	400	780	800	56		9205	820

ZSY Reducer power

ratio <i>i</i>	speed/rmin ⁻¹		Specifications													
	input <i>n</i> ₁	output <i>n</i> ₂	160	180	200	224	250	280	315	355	400	450	500	560	630	710
	Input power <i>P</i> ₁ /kW															
22.4	1500	67	34	51	68	98	131	182	270	400	530	780	1065	1450	1865	—
	1000	44	24	35	48	68	91	128	185	262	355	540	750	1025	1325	1905
	750	33	18	27	37	52	70	97	135	215	275	415	580	800	1030	1485
25	1500	60	32	46	63	96	115	157	240	365	470	705	1020	1405	1865	—
	1000	40	22	31	43	66	80	108	163	250	315	465	705	975	1325	1905
	750	30	16	24	33	51	60	84	122	195	240	350	540	750	1030	1485
28	1500	54	29	42	59	86	113	142	220	325	425	625	945	1260	1800	—
	1000	36	20	29	41	60	75	98	148	215	280	420	650	870	1245	1760
	750	27	15	22	31	46	56	76	114	160	210	310	500	670	960	1355
31.5	1500	48	26	37	51	79	95	127	197	290	395	560	840	1140	1600	—
	1000	32	17	26	35	55	63	86	132	195	270	370	585	790	1110	1565
	750	24	14	20	27	42	49	65	100	145	200	280	450	605	855	1200
35.5	1500	42	23	34	47	70	88	117	178	275	350	510	755	1025	1450	—
	1000	28	15	23	32	48	59	80	118	180	235	340	520	710	1000	1410
	750	21	12	18	25	37	44	61	90	140	175	255	405	545	750	1090
40	1500	38	21	30	42	64	79	107	158	235	325	465	675	930	1300	—
	1000	25	17	21	29	40	53	71	108	160	210	315	465	640	900	1315
	750	19	11	16	22	31	41	55	80	125	155	235	360	495	680	1015
45	1500	33	17	24	34	46	70	96	142	215	280	410	615	850	1130	—
	1000	22	12	16	24	32	47	64	95	145	185	280	425	590	770	1150
	750	17	9	12	18	25	36	50	74	110	140	210	320	450	600	885
50	1500	30	15	22	32	46	63	85	128	195	245	360	540	750	1030	1490
	1000	20	11	15	22	31	43	59	85	130	165	240	370	520	710	1030
	750	15	8	12	17	24	32	43	65	95	125	180	290	400	550	795
56	1500	27	15	21	31	43	56	76	112	170	220	310	480	675	955	1340
	1000	18	10	15	22	30	38	52	77	115	145	210	330	470	660	930
	750	13.4	8	11	17	23	28	40	58	90	110	160	255	360	510	715
63	1500	24	12	17	23	37	45	61	102	145	195	280	425	605	860	1170
	1000	16	8	12	16	25	30	42	70	100	130	190	290	420	600	810
	750	12	6	9	12	20	23	32	52	75	100	140	225	325	460	620
71	1500	21	11	17	23	33	40	56	90	130	185	245	390	540	770	1045
	1000	14	8	11	15	23	27	38	60	90	115	170	270	370	540	725
	750	10.6	6	9	12	18	21	29	45	65	90	125	210	285	410	555
80	1500	18.8	9	13	18	26	36	51	80	115	155	225	340	470	675	960
	1000	12.5	6	9	12	18	24	34	54	80	100	150	240	330	470	665
	750	9.4	4	7	10	14	19	27	42	60	80	110	185	250	360	510
90	1500	16.7	8	12	18	25	33	46	74	105	140	200	305	395	590	765
	1000	11.1	6	8	12	17	22	30	49	70	95	130	200	278	405	530
	750	8.3	4	6	9	13	17	23	37	55	70	100	160	210	300	405
100	1500	15	8	11	16	24	30	43	60	—	—	—	—	—	—	—
	1000	10	5	7	11	16	21	29	40	—	—	—	—	—	—	—
	750	7.5	4	6	8	13	16	22	30	—	—	—	—	—	—	—

note: *i*=100 Space is simplified Series design, When need to supplement.

ZFY Series reducer

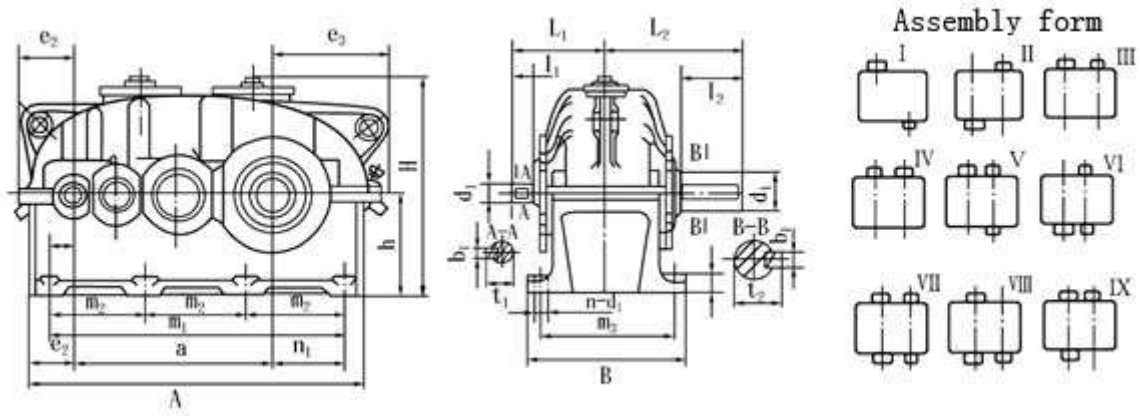

Specification	A	B	H ≈	a	i=22.4~71					i=80~100					d ₁ (m6)	b ₁	L ₂	b ₂	t ₂
					d ₁ (m6)	t ₁	L ₁	b ₁	t ₁	d ₁ (m6)	t ₁	L ₁	b ₁	t ₁					
160	600	290	375	352	24	36	166	8	27	19	28	158	6	21.5	75	105	245	20	79.5
180	665	320	435	395	28	42	187	8	31	22	36	181	6	24.5	85	130	285	22	90
200	745	355	492	440	32	58	218	10	35	22	36	196	6	24.5	95	130	300	25	100
224	840	390	535	496	38	58	233	10	41	24	36	211	8	27	100	165	355	28	106
250	930	450	589	555	42*	82*	282	12	45	32	58	258	10	35	110	165	380	28	116
280	1025	500	662	620	48	82	307	14	51.5	38	58	283	10	41	130	200	440	32	137
315	1160	570	749	699	48	82	337	14	51.5	42	82	337	12	45	140	200	470	36	148
					i=22.4~35.5					i=40~90									
355	1280	600	870	785	60	105	380	18	64	48	82	357	14	51.5	170	240	530	40	179
400	1420	690	968	880	65	105	410	18	69	55	82	387	16	59	180	240	560	45	190
450	1610	750	1067	989	70	105	450	20	74.5	60	105	450	18	64	220	280	640	50	231
					i=22.4~45					i=50~90									
500	1790	830	1170	1105	80	130	515	22	85	65	105	490	18	69	240	330	730	56	252
560	2010	910	1320	1240	95	130	530	25	100	75	105	505	20	79.5	280	380	820	63	292
630	2260	1030	1480	1395	110	165	625	28	116	85	130	590	22	90	300	380	880	70	314
710	2540	1160	1655	1565	120	165	685	32	127	90	130	650	25	95	340	450	1010	80	355

note* When i=63 and i=71, Axis stretch size d₁=32, l₁=58.

Specification	C	m ₁	m ₂	m ₃	n ₁	n ₂	e ₁	e ₂	e ₃	h	Bolt hole		Weight/kg	oil/L
											d ₃	n		
160	32	510	170	245	38	120	83	107	188	180	18.5	8	170	10
180	32	570	190	275	37.5	137.5	85	109	209	200	18.5		205	14
200	40	630	210	300	40	150	97.5	128	238	225	24		285	19
224	40	705	235	335	43.5	165.5	110.5	141	263	250	24	8	395	26
250	50	810	270	380	60	195	120	158	293	280	28		540	36
280	50	855	285	430	35	200	120	160	325	315	28		750	53
315	63	960	320	490	40	221	143	189	364	355	35		1030	78
355	63	1080	360	520	42.5	252.5	143	188	398	400	35	8	1400	115
400	80	1200	400	590	45	275	155	215	445	450	42		1950	160
450	80	1350	450	650	48	313	178	240	505	500	42		2636	220
500	100	1500	500	710	59	336	200	277	557	560	48	8	3800	300
560	100	1680	560	790	70	370	235	324	624	630	48		5100	450
630	125	1890	630	890	72.5	422.5	255	344	694	710	56		7060	520
710	125	2130	710	1000	92.5	472.5	297.5	400	780	800	56		9205	820

ZFY Series Gearbox Specifications

Ratio i	Speed (r/min)		Size													
	输入 n_1	输出 n_2	180	200	225	250	280	320	360	400	450	500	560	630	710	800
			Rated Power (KW)													
100	1500	15	-	-	-	-	-	-	99	130	190	290	400	540	780	1100
	1000	10	-	-	-	-	-	-	66	87	125	195	265	360	520	750
	750	7.5	-	-	-	-	-	-	50	65	95	145	205	270	400	560
112	1500	13.4	9.2	15	21	29	40	59	88	115	170	255	360	480	690	990
	1000	8.9	6.1	10	14	20	27	40	59	78	115	170	240	320	470	670
	750	6.7	4.6	7.5	11	15	20	29	44	59	85	130	185	245	355	510
125	1500	12	9.2	12	18.5	26	36	52	81	105	150	230	320	430	610	890
	1000	8	6.1	8	12.5	17.5	24	35	54	70	100	155	215	285	410	590
	750	6	4.6	6	9.3	13	18	26.5	41	53	75	115	165	215	310	440
140	1500	10.7	8.4	11	16.5	23	32	46	72	92	135	205	290	380	550	800
	1000	7.1	5.6	7.3	11	16	21.5	31	48	61	90	135	195	255	370	530
	750	5.4	4.2	5.5	8.3	12	16	23	36	46	68	105	145	190	288	400
160	1500	9.4	7.5	9.6	14.5	20	28	41	64	81	120	180	255	340	490	710
	1000	6.3	5	6.4	9.7	14	18.5	27.5	43	54	80	120	170	225	330	470
	750	4.7	3.8	4.8	7.6	10	14	21	32	41	60	92	130	170	250	360
180	1500	8.3	6.6	8.4	13	19	25	37	57	70	105	160	225	300	440	630
	1000	5.6	4.4	5.6	8.7	12.5	17	25	38	47	70	105	150	200	295	420
	750	4.2	3.3	4.2	6.5	9.5	13	18.5	29	35	53	82	115	155	220	320
200	1500	7.5	5.6	7.5	12	15.5	22	33	51	64	95	145	205	270	390	560
	1000	5	3.7	5	8	10.5	14.5	22	34	43	63	97	135	180	260	370
	750	3.8	2.8	3.8	6	8	11.5	17	26	32	48	73	105	135	200	280
224	1500	6.7	4.8	6.7	10.5	14	20	29	45	57	83	130	185	240	360	510
	1000	4.5	3.2	4.5	7	9.3	13.5	20	30	38	55	87	125	160	240	340
	750	3.3	2.4	3.4	5.3	7	10.5	15	23	28.5	42	66	94	120	180	255
250	1500	6	4.5	6.1	9.5	12.5	17.5	26	41	51	73	115	165	215	320	450
	1000	4	3	4.1	6.3	8.5	12	17.5	27.5	34	49	77	110	145	215	300
	750	3	2.3	3.1	4.8	6.5	9	13	20.5	25.5	37	58	83	110	160	225
280	1500	5.4	3.9	5.3	8.2	11	15.5	23	37	46	66	100	145	195	280	400
	1000	3.6	2.6	3.5	5.6	7.5	10.5	15.5	24.5	31	44	67	97	130	185	265
	750	2.7	2	2.7	4.2	5.6	8	12	19	23	34	51	73	96	140	200
315	1500	4.8	3.5	4.7	7.5	9.5	13.5	21	32	42	59	92	130	175	250	360
	1000	3.2	2.3	3.1	5.1	6.5	9	14	21.5	28	39	61	87	115	165	240
	750	2.4	1.8	2.4	3.8	5	7	10.5	16.5	21	30	47	66	88	125	180
355	1500	4.2	2.9	4	6.5	8.5	12	18	29	37	52	83	115	155	225	320
	1000	2.8	1.9	2.7	4.5	6	8.5	12	19.5	24.5	35	55	77	105	150	215
	750	2.1	1.5	2	3.3	4.5	6.5	9.5	14.5	18.5	26.5	42	59	78	115	160
400	1500	3.8	2.6	3.6	6	8	11	16.5	26	33	46	72	100	135	195	270
	1000	2.5	1.7	2.4	4	5.3	7.5	11	17.5	22	31	48	68	90	130	180
	750	1.9	1.3	1.8	3	4	6.5	8.3	13.5	16.5	23.5	37	52	68	99	135
450	1500	3.3	2.3	3.2	5	7	10	13.5	21.5	29	40	65	93	125	175	250
	1000	2.2	1.5	2.1	3.5	4.7	6.6	9	14.5	19.5	26.5	44	62	83	115	170
	750	1.7	1.2	1.6	2.6	3.5	5.1	6.8	11	14.5	20	33	47	63	89	125
500	1500	3	2.1	2.9	4.2	6	9.1	12	19.5	26	36	59	82	110	155	225
	1000	2	1.4	1.9	2.8	4	6.1	8	13	17.5	24	39	55	73	105	150
	750	1.5	1.1	1.5	2.1	3	4.6	6	9.6	13	18	30	42	55	79	115

Lubrication&Cooling means

1. As usual it apply to oil bath and natural cooling.If you request cooling coil to cool or forced pump lubrication ,please contact us.

When high speed grade’s circulate speed $V < 2.5m/s$,OR environmental temperature during 35~50,choose mid extreme pressure gear oil N320/VG320

When high speed grade’s circulate speed $V < 2.5m/s$,OR apply to circular lubrication,choose mid extreme pressure gear oil N220/VG220

- 2. For bearing, recommend splash oil lubrication and brand is same as for gear.
- 3. When last stage center distance (spec.a)» 400, recommend forced lubrication,plz check appendix D.
- 4. ZDY,ZLY to be adviced to match the oil cooler,when ratio>40 for ZSY ,no cooler

Installation,usage and maintance

- 1. Plz insure the input shaft axis and output shaft axis of gearbox lies in the same one shaft with connected part’s shaft axis.The error cannot above allowable value for coupling to be used.If you use triangle belt as input drive,belt should reduce the unbalance quality through cutting manufacture.
- 2. Done with the installtion ,plz pure the lubrcication into the oil bath of housing ,oil surface should reach the height of oil dipstick (between the upper limit line and floor level line).
- 3. Before it is driven, turn by hand to confirm if it is flexible without lock , then drive no load,term is 2 hours. If you find out noice, oil leakage, libriation ,plz eliminate it
- 4. The first use for gearbox, after driving 20 days, plz change the new oil.Should exam the quality of oil, plz change it in time.And exam the height of oil surface, if it is lower than mid line of dispatch, need to be supplied. As usual ,change the oil of gearbox which work for 8 hours every day every three month. Its working time within 8 hours, oil can be changed for every 6 months
- 5. If you find out the oil ’s temperature rise above 70 °C or oil’s temperature is above 100 °C, quality of oil is low down and has deviant noise . Plz stop and exam.

Selection for gearbox

P_1 means nominal power,if actual input speed’s difference for reducer beyond 4% with someone (1500,1000,750),please as actual input speed to convert :

Example

one set of belt form transmission machine’s speed reducer to be used to transport big goods, driven by motor, input speed $n_1=1200r/min$, ration $i=4.5$, load power $P_2= 380kw$, every day it work for 24hours, Plz choose a model.

Step 1 Check up by appendix A and get to: belt form transmission speed reducer’s load is medium concussion, if reducer is broken it will lead to the whole production line is stop production, and check up table 1,2 to get up: $K_A=1.5, S_A=1.5$,

$P_{2m}=P_2 \times K_A \times S_A=380 \times 1.5 \times 1.5=855kw$

Request $P_{2m} \leq P_1$

Step 2 $n_1=1200r/min$ near to 1000r/min, $i=4.5$, check up and get ZDY355, $i=4.5, n_1=1000r/min, P_1=953kw$.When $n_1=1200r/min$,to convert nominal power : $P_1=953 \times 1200/1000=1143.6kw, P_{2m}=855kw \leq P_1=1143.6kw$,so ZDY355 is Ok.

Table 1 Working situation factor KA

Prime motor	Working time everyday(hour)	KA		
		Light impulsive load(U)	Mid impulsive load(M)	Heavy impulsive load(H)
Motor/steam turbine/hydraulic machinery	~3	0.8	1	1.5
	>3~10	1	1.25	1.75
	>10	1.25	1.5	2

4-6 set cyclinder engine	~3	1	1.25	1.75
	>3~10	1.25	1.5	2.25
	>10	1.5	1.75	2.5
1-3 set cyclinder engine	~3	1.25	1.5	2
	>3~10	1.5	1.75	2.25
	>~10	1.75	2	2.5

Appendix A (Reducer gearbox Loading classification)

Name of machine	Loading classification	Name of machine	Loading classification
Construction machine		Textile lathe	
Concrete batch plant	M	Feeding machine	M
Winch machine	M	Loom	M
Road Construction machine	M	Printing&drying lathe	M
Chemical		Prepared bucket	M
Mixer(hydraulic)	U	Rubber machine	
Mixer(Semi-hydraulic)	M	Calendar	M
Centrifugal body(heavy)	M	Extruder	H
Centrifugal body(light)	U	Banduary	M
Cooling roller	M	Kneader	H
Dry rooler	M	Roller mill	H
Mixer	M		

(More reference data such as plastic machine,engineer,crane and so on, please contact us, we will supply with it.)

Table 2 Safety factor S_A

Result for reducer's effectiveness lose	General loss	Serious loss	Serious badly loss
		Single machine stop production	Whole production line stop production
S_A	1.1~1.3	1.3~1.5	1.5~1.7



Always chase the first since 1995

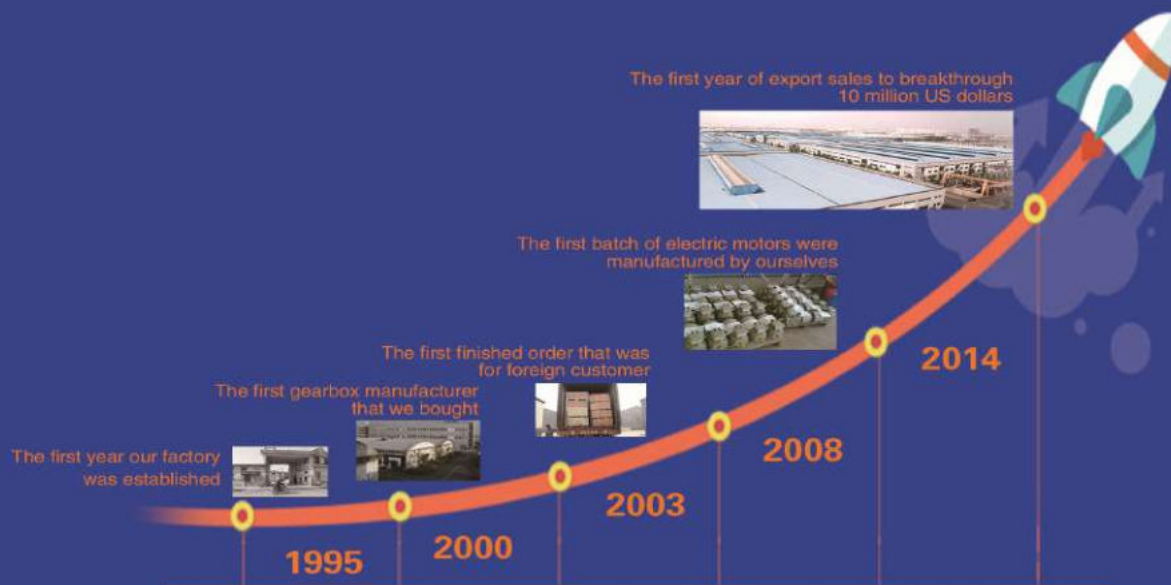

Tel:+86-535-6330966

Mobile:+86-18563806647

E-mail: info@sogears.com

Viber/Line/Whatsapp/Wechat: 008618563806647

Web: www.sogears.com(Skype: qingdao411)

Headquarters Address: Wujin, Changzhou City, Jiangsu Province,China